

UDC 621.7

Milenin A.
Kustra P.OPTIMIZATION OF EXTRUSION AND WIRE DRAWING OF MAGNESIUM ALLOYS
USING THE DISTRIBUTED COMPUTING

In the majority of the cases the alloys of magnesium are characterized by low technological plasticity, because of their hexagonal crystal structure with only basal slip and twinning as the major operative deformation mechanisms [1–2]. Usually this problem is solved by increasing deformation temperature [2]. However, more essential problem is the fact that the interval of the permissible parameters of deformation is very small. It is known that comparatively insignificant changes in the speed of extrusion, initial temperature, temperature of container lead to the fracture [2]. For example, the process of the extrusion of the Mg alloys MgCa0.8 and Ax30 is investigated in the work [3]. Experiments were performed at Hannover University [3]. It was shown that an increase in the speed of extrusion with 2 mm/s to 8 mm/s leads to the fracture. From the other side, the less a temperature of the deformation caused the rapid exhaustion of the resource of the material plasticity. In this case it is necessary to develop a model of fracture of examinee alloys [4, 5]. Thus, the solution of the problem of the definition of the optimum parameters of the deformation of magnesium alloys must consider both the possibility of overheating material and its limited plasticity at lower temperatures. In order to resolve this problems software based on the finite element method have been developed [6–9].

The problem that arises in the optimization needs to perform a large number of three-dimensional FEM simulations of different variants of the process. Performing these calculations of in sequential mode requires not real time, that way it was necessary to limit the number of influencing factors. In this paper a modification of the earlier FEM programs, allowing the use of distributed computing and clusters of computers was performed. The programs were developed as a service Extrusion-Grid in cluster infrastructure PL-Grid [10, 11].

For the simulation of flow stress the equation of Henzel-Szpittel is used:

$$\bar{\sigma} = A \exp(m_1 t) t^{m_9} \bar{\varepsilon}^{-m_2} \exp(m_4 / \bar{\varepsilon}) (1 + \bar{\varepsilon})^{m_5 t} \exp(m_7 \bar{\varepsilon}) \bar{\xi}^{-m_3} \bar{\xi}^{m_8 t}, \quad (1)$$

where $\bar{\sigma}$, $\bar{\varepsilon}$, $\bar{\xi}$ – effective stress, effective strain and effective strain rate, respectively;

t – temperature.

For the MgCa0.8 and Ax30 alloys are used the approach, based on the inverse analysis [4]. The following coefficients of equation (1) for extrusion conditions are obtained.

• MgCa0.8: $A = 1413,33$; $m_1 = -0,0046301$; $m_2 = 0,53755$; $m_3 = 0,13458$; $m_4 = -1,3544$; $m_5 = 0,0$; $m_7 = 0,0$; $m_8 = 0,0$; $m_9 = -0,0$;

• Ax30: $A = 17,623$; $m_1 = -0,0046301$; $m_2 = 0,41715$; $m_3 = -0,26152$; $m_4 = -0,0061179$; $m_5 = -0,0091911$; $m_7 = 0,45429$; $m_8 = 0,0015854$; $m_9 = 0,81829$.

According to the work [4] the critical damage failure criterion is established:

$$\psi = \frac{\bar{\varepsilon}}{\varepsilon_f(k_f, t, \bar{\xi})}, \quad (2)$$

where ε_f – effective fracture strain k_f – triaxility factor.

To describe the value of effective fracture strain the following formula can be applied:

$$\varepsilon_f = d_1 \exp(-d_2 k) \exp(d_3 t) \bar{\xi}^{d_4}. \quad (3)$$

The values of the coefficients of equation (3) are determined by the minimization of the square-least technique comparing the value of ε_f and the results obtained from processing of the experimental results of the compression and the tension tests. The following values of coefficients are obtained:

- MgCa0.8: $d_1 = 0,0461$; $d_2 = 0,4759$; $d_3 = 0,01022$; $d_4 = -0,07009$.
- Ax30: $d_1 = 0,0153$; $d_2 = 0,129$; $d_3 = 0,0158$; $d_4 = -0,245$.

FEM MODELS OF EXTRUSION AND DRAWING PROCESSES FOR MAGNESIUM ALLOYS

Extrusion

Typically, extrusion process consists of the three consequent stages: initial stage; stage of steady-state material flow and final stage. During the last one the punch slows down and stops. From the practical point of view the most important stage is steady-state one because the product shape and its properties are formed. Thus steady-state stage of extrusion process can be simulated with acceptable accuracy using Euleran approach [6, 12].

In the present work the material is considered as incompressible rigid-viscoplastic continua and elastic deformation are neglected. The system of governing equation includes:

– equilibrium equations:

$$\sigma_{ij,i} = 0; \quad (4)$$

– compatibility condition:

$$\xi_{ij} = \frac{1}{2}(v_{i,j} + v_{j,i}); \quad (5)$$

– constitutive equations:

$$S_{ij} = \frac{2\bar{\sigma}}{3\bar{\xi}} \xi_{ij}; \quad (6)$$

– incompressibility equation:

$$v_{i,j} = 0; \quad (7)$$

– energy balance equation:

$$\rho c t = k(t_{,i})_{,i} + \beta \bar{\sigma} \bar{\xi} \quad (8)$$

and expression for flow stress (1),

where σ_{ij} – stress;

ξ_{ij} – strain rate and v_i – velocity component respectively;

S_{ij} – deviator stress tensor;

β – heat generation efficiency which is usually assumed as $\beta = 0,9-9,95$;

ρ – density;

c – specific heat and k – thermal conductivity.

In equation (4)-(8) summation convention is used. Equations (4)-(7) were transformed into discrete form by means of virtual work-rate principle and finite element technique resulting in non-linear system of algebraic equations where nodal values of velocity components and mean stress are considered as independent variables. Velocity and mean stress are approximated by quadratic and

linear shape function respectively within the 15-node prismatic elements. Energy balance equation (8) is treated by means of Galerkin method. Iterative updating of heat generation and flow stress provides thermo-mechanical coupling of the problem. The container, punch and die are treated as rigid bodies with specified friction and heat transfer conditions.

Finite elements mesh is generated automatically for space domain that includes the billet in container and part of the product having sufficient length to be rigid at its front end. Product shape is arbitrary. Source data for mesh generation include geometrical contour of container, contour of the product and contour of the pre-chamber. These geometrical data can be imported from CAD system. Other data are the length of container, the length of pre-chamber and the length of bearing [6].

The tensor ε_{ij} is calculated by integration along the flow lines:

$$\varepsilon_{ij} = \int_0^{\tau} \xi_{ij}(\tau) d\tau = \sum_{p=1}^{p=p_{\tau}} \xi_{ij}^{(p)} \Delta\tau^{(p)}, \quad (9)$$

where: $\Delta\tau^{(p)}$ – time increment;

$\xi_{ij}^{(p)}$ – strain rate tensor determined according to equation:

$$\xi_{ij}^{(p)} = \sum_{n=1}^{n_{nd}} N_n \xi_{ijn}, \quad (10)$$

where N – finite element shape functions;

ξ_{ijn} – nodal strain rate tensor for current finite element;

n_{nd} – number of nodes in element.

The points of flow lines are determined on the basis of the values of the velocity at point p , which are calculated according to the formula:

$$v_i^{(p)} = \sum_{n=1}^{n_{nd}} N_n v_{in}. \quad (11)$$

The calculation of the position of the next point $(p + 1)$ of flow line is carried out according to the equation:

$$x_i^{(p+1)} = x_i^{(p)} + v_i^{(p)} \Delta\tau. \quad (12)$$

The integration of the critical damage failure criterion is achieved along the flow lines:

$$\psi = \int_0^{\tau} \frac{\bar{\xi}}{\varepsilon_f(k_f, t, \bar{\xi})} d\tau \approx \sum_{m=1}^{m=m_{\tau}} \frac{\bar{\xi}^{(m)}}{\varepsilon_f(k_f, t, \bar{\xi})} \Delta\tau^{(m)}. \quad (13)$$

The developed model is based on the three-dimensional approach only. However, the speed of solution of one problem on the Zeus cluster in sequence mode is not more than 30 minutes because of the rational selection of the numerical parameters of mesh.

Wire drawing

For model of wire drawing in heated die solution of boundary problem is obtained using variation principle of rigid-plastic theory according equations (1)–(7) [4, 13]. The stationary formulation of the boundary problem is used. The strain tensor ε_{ij} is calculated by integration of strain rate tensor along the flow lines.

Thermal problem in metal was solved by applying the following method. The passage of the section through the zone of deformation was simulated. For this section at each time step the non-stationary temperature problem was examined:

$$\lambda \left(\frac{\partial^2 t}{\partial r^2} + \frac{1}{r} \frac{\partial t}{\partial r} \right) + Q_d = c\rho \frac{dt}{d\tau}. \quad (14)$$

where $Q_d = 0.9\sigma_s \xi_i$ is the deformation power, c is the specific heat; ρ is the alloy density, τ is the time, λ is the thermal conductivity coefficient (the following equations are used for MgCa0.8 and Ax30 alloys: $c = 1013,4 + 0,441t$, $\rho = 1741,4 - 0,173t$, $\lambda = 156,32 - 0,023t$). Heat exchange between the alloy and the die is defined as:

$$q_{conv} = \alpha(t - t_{die}). \quad (15)$$

where t_{die} is the distribution of die temperature on contact area, which obtained from temperature solution in die, α is the heat exchange coefficient.

The generation of heat from the friction is calculated according to the formula:

$$q_{fr} = 0.9\sigma_\tau v_\tau. \quad (16)$$

The model of temperature distribution in the die is based on the solution of Fourier equation in the cylindrical coordinate system. The results of measuring temperature on the contact of die with the device for drawing were used as the boundary conditions. The thermocouples and the electronic system of the control of temperature were used for measurement.

Boundary conditions on the contact of die with the metal were assigned with the aid of the dependence:

$$q_{conv} = \alpha(t - t_{metal}), \quad (17)$$

where t_{metal} is the distribution of metal temperature on contact area obtained from temperature solution in metal.

PARALLEL FEM CODE FOR OPTIMIZATION OF EXTRUSION PROCESSES ON BASE OF PL-GRID INFRASTRUCTURE

Parallelization of the models described above is made on the basis of the following algorithm.

1. Initial data for the model is given as a range of possible changes in the parameters. For example, pressing speed is specified as a set of values 1–10 mm/s, and extrusion temperature as values 380–440 °C. It is also possible to set the different geometry of the channel profile.

2. At the next stage, the program generates the variants based on the theory of the factor experiment.

3. All generated variants are run in parallel with the calculation of the PL-Grid infrastructure. Calculation time of all variants equal to the time of calculation of one. Based on the result of the calculation is chosen the best options.

Illustration of the sequence using the program in the infrastructure shown in fig. 1. During develop a parallel version of software the Intel Fortran compiler and openmp library are used. Example of geometry optimization for profile extrusion is shown on fig. 2. Optimal variant for extrusion of shape was selected because torsion and bending of the profile are the smallest of all the variants considered. Because the calculations were carried out in parallel computational system PL-Grid optimization time is equal to the time of one simulation.

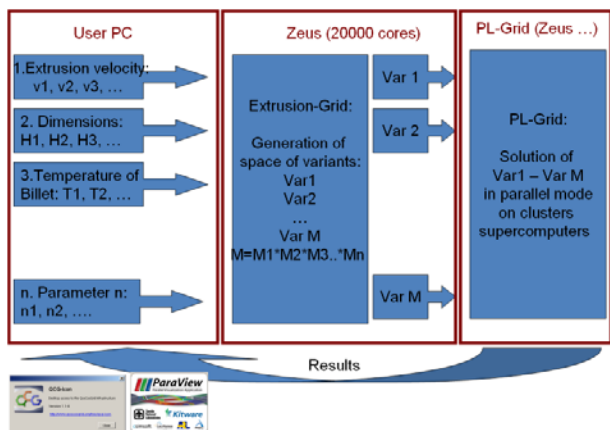

Fig. 1. Illustration of the parallel program Extrusion-Grid in the infrastructure PL-Grid

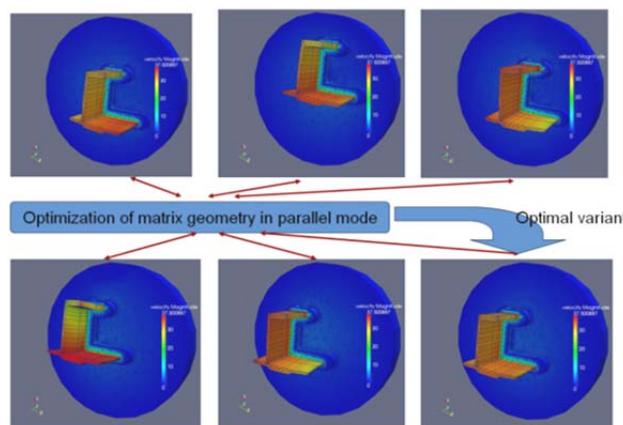

Fig. 2. Example of optimization in Extrusion-Grid software for PL-Grid computation system

EXAMPLE OF OPTIMIZATION

Extrusion

As an example of optimizing, consider the choice the temperature and extrusion speed for rod of magnesium alloy Ax30. Numerical simulations were carried out for the following conditions. The diameter of billet is of 120 mm, the pressed profile - bar with the diameter of 30 mm, speed of extrusion is varies in the range 1–10 mm/s. Initial temperature of billet is varies in the range 380–440 °C, the temperature of container and matrix is of 380 °C. Two variants of the calculation are shown as examples: speed of extrusion of 2 mm/s (variant 1) as well as 8 mm/s (variant 2) for initial temperature of billet 400 °C. The variant 1 corresponds to the extrusion without the defects (fig. 3, c), the variant 2 corresponds to the appearance of the defects (fig. 4, c). The results of calculations are represented in fig. 3 (variant 1) and fig. 4 (variant 2). As the obtained results showed that the temperature of material grows to 475 °C, that however lower than the temperature of the solidus line of this alloy (approximately 520 °C). The value of the criterion of fracture is also lower than 1.0, consequently extrusion must occur without the defects, which corresponds to experiment. In the case of variant 2 temperatures increase to 540 °C, this must lead to the inevitable appearance of defets (fig. 4). This result also corresponds to the facts observed in the experiment [3].

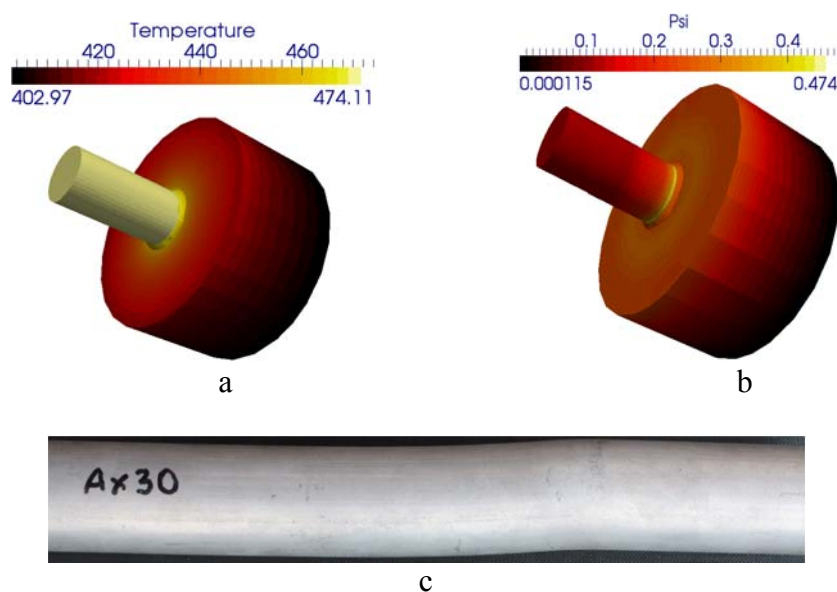

Fig. 3. Simulation of the extrusion of alloy Ax30, variant 1:

a – temperature; b – fracture criterion; c – results of the extrusion of alloy Ax30 with the speed of punch 2 mm/s

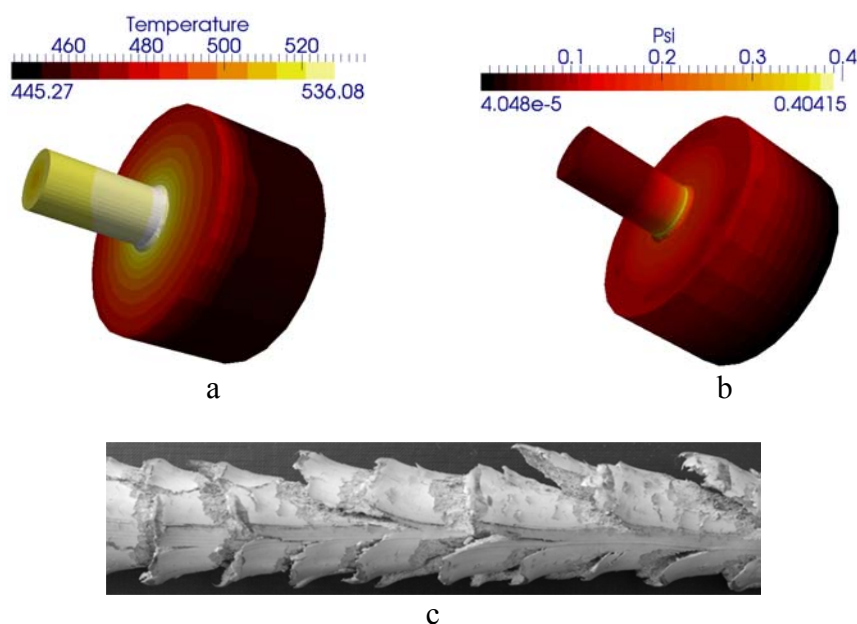

Fig. 4. Simulation of the extrusion of alloy Ax30, variant 2:
 a – temperature; b – fracture criterion; c – results of the extrusion of alloy Ax30 with the speed of punch 8 mm/s

Wire drawing

Cold drawing process of magnesium wires is practically impossible. That is why new technology of drawing in heated die for thin wires with diameter less than 1 mm was proposed. In this technology drawing tool is heated to temperature about 400 °C. Cold wire is heating by die to recrystallization temperature (about 300 °C) and then is deformed. Such conditions caused that multi pass drawing process without annealing is possible.

Temperature of wire in proposed process is strongly dependent on drawing velocity, shape of tool and tool temperature. Predict of wire temperature in this nonconventional process is very difficult but can be calculated using numerical simulation. In this case Drawing2d software was used. Calculations for initial wire diameter 0.5 mm, final diameter 0.456 mm (elongation 1.2), drawing angle 4°, 6° and drawing velocity 10 mm/s, 200 mm/s were performed. Results of these simulations are present in table 1.

Table 1

Results of numerical simulation of drawing process in heated die

No	<i>Alfa</i>	v , mm/s	<i>Psi</i>	<i>DefMES/Def</i>	P_y , N	S_y , Mpa	S_p , MPa	S_y/S_p	$Temp$, C
1	4	10	0.8724	1.1421	6.97	41.99	76.43	0.5494	341.16
2	4	200	2.9522	1.1233	7.12	42.84	117.59	0.3643	125.01
3	6	10	1.5502	1.2135	6.68	40.23	89.03	0.4519	320.76
4	6	200	3.6261	1.2744	7.00	42.13	135.36	0.3112	120.31

In Table 1 following marks were used *Alfa* – drawing angle; v – drawing velocity; *Psi* – damage criterion; *DefMES / def* – the ratio of the maximum deformation intensity in deformation zone calculated by FEM to the same value calculated using engineering methodology; P_y – drawing force, S_y – drawing stress; S_p – yield stress in the plane of the metal out of the die; S_y/S_p – the ratio of drawing stress to yield stress; *temp* – the temperature of the metal at the exit of the deformation zone.

Results presented in table 1 shows that as it was said before temperature of wire in drawing process with heated die is strongly dependent on drawing velocity and drawing angle (shape of tool). Value of damage criterion ($Psi < 1$) break criterion ($S_y/S_p < 1$) and recrystallization criterion ($Temp \geq 300 \text{ }^\circ\text{C}$) are correct only for first variant of simulation (table 1). That is why verification of drawing process in heated die was performed for conditions applied for variant 1 on own construction device [14] (fig. 5) allows to carry out drawing process in heated die.

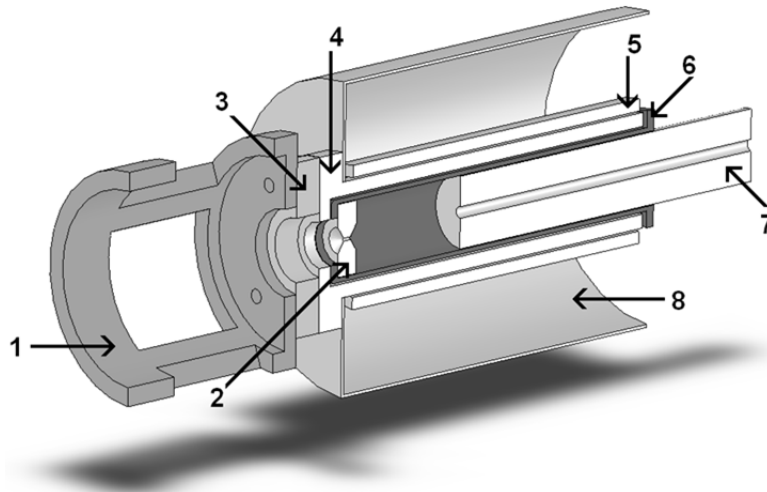

Fig. 5. Equipment for wire drawing in heated die:

1 – handle; 2 – drawing die; 3 – insulation pad; 4 – main furnace tube; 5 – heating element; 6 – tube with tool; 7 – tube for changing the size of heating zone; 8 – housing

The drawing process was done for deformation scheme $\phi 1.0 \text{ mm}$ to $\phi 0,1 \text{ mm}$ with elongation 1.21. Drawing velocity was 10 mm/s, temperature of the die $330 \text{ }^\circ\text{C}$ and drawing angle 4° . The result of drawing process is shown in fig. 6. Experiment shows that proposed technology is working correctly with biocompatible magnesium alloys as MgCa0.8 and Ax30.

Drawing process in heated die was consisting of 25th passes without annealing. Microstructure of wire with diameter 0,1 mm after last pass is presented in fig. 6. In proposed technology heating die causes full recrystallization in drawn material. As can be seen from fig. 8a final wire has high plasticity as evidenced by the formation of the knot.

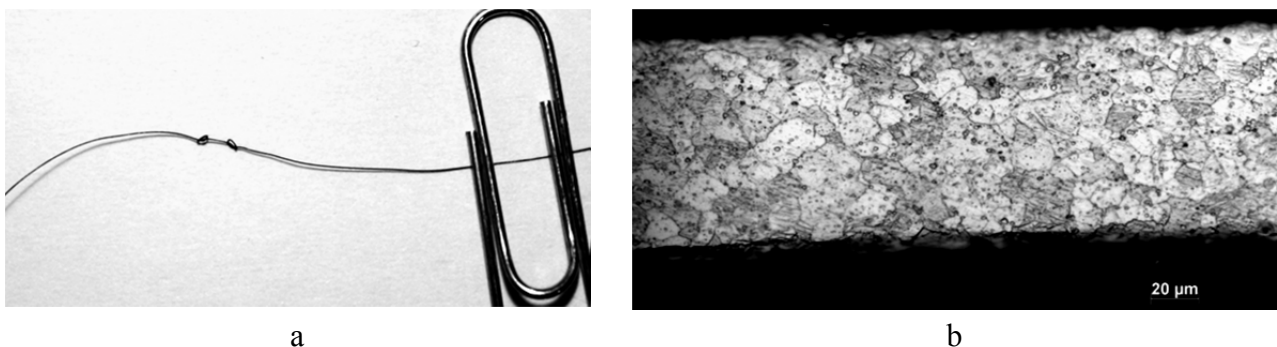

Fig. 6. Wire with diameter 0,1 mm of MgCa0.8 after drawing:
a – in macro scale; b – microstructure

CONCLUSIONS

FEM programs for optimization of extrusion and wire drawing processes was proposed allowing the use of distributed computing and clusters of computers was performed.

In present paper the process of manufacturing of thin wire of magnesium alloy AX30 and MgCa0.8 consists of two steps extrusion and drawing in heated die was shown.

Optimization of production processes for cracking criterion was done using numerical modeling. Calculations were helpful in obtaining of correct conditions of extrusion and drawing process. In this case super computer was used. Because extrusion process is time consuming from numerical point of view calculation were performed on super computer Zeus. Because the calculations were carried out in parallel mode, optimization time is equal to the time of one simulation.

The new technology of drawing process in heated die was proposed. The technology made it possible to obtain wire 0.1 mm from the billet 1.0 mm without the application of annealing between the passages.

Financial assistance of the Ministry of Science and Higher Education of Poland, project no. 2012/05/B/ST8/01797 is acknowledged.

REFERENCES

1. G. Liu, J. Zhou, J. Duszczyk: *Prediction and verification of temperature evolution as a function of ram speed during the extrusion of AZ31 alloy into a rectangular section*, *Journal of Materials Processing Technology*, 186 (2007), 191–199.
2. R. Ye. Lapovok, M. R. Barnett, C. H. J. Davies: *Construction of extrusion limit diagram for AZ31 magnesium alloy by FE simulation*, *Journal of Materials Processing Technology*, 146 (2004), 408–414.
3. A. Milenin, P. Kustra, J.-M. Seitz, Fr.-W. Bach, D. Bormann: *Production of thin wires of magnesium alloys for surgical applications*, 2010, *Conference Proceedings of the Wire Association International, Inc. - Wire and Cable Technical Symposium, 80th Annual Convention, May 2010, Pages 61-70, Milwaukee, WI; Code 93453*.
4. A. Milenin, P. Kustra: *Mathematical Model of Warm Drawing Process of Magnesium Alloys in Heated Dies*, *Steel Research International*, 81(9), spec. ed. (2010), 1251–1254.
5. W. J. Kim, H. K. Kim, W. Y. Kim, S. W. Han: *Temperature and strain rate effect incorporated failure criteria for sheet forming of magnesium alloys*, *Materials Science and Engineering A*, 488 (2008), 468–474.
6. A. Milenin *Mathematical modeling of operations of correcting the dies for section extruding Metallurgicheskaya i Gornorudnaya Promyshlennost Issue 1-2, 2000, Pages 64-66, ISSN: 05435749*
7. A. Milenin, P. Petrov, M. Petrov, E. Krutina *Numerical model of fracture in magnesium alloys during forming processes // W: Metal Forming 2012 : proceedings of the 14th international conference on Metal Forming: September 16–19, 2012, Krakow, Poland / eds. J. Kusiak, J. Majta, D. Szeliga. — Weinheim : Wiley-VCH Verlag GmbH & Co. KGaA, cop. 2012. (Steel Research Int.; spec. ed.). ISBN 978-3-514-00797-0. P. 847–850.*
8. A. Milenin, D. J. Byrska, O. Grydin: *The multi-scale physical and numerical modeling of fracture phenomena in the MgCa0.8 alloy*, *Volume 89, Issue 11-12, June 2011, Pages 1038-1049, DOI: 10.1016/j.compstruc.2011.01.003*
9. Milenin, A., Kustra, P., Seitz, J.-M., Bach, Fr.-W., Bormann, D. *Development and validation of a mathematical model of warm drawing process of magnesium alloys in heated dies*, 2011, 10p, *WAI's 81st Annual Convention, Interwire 2011; Atlanta, GA; 3 May 2011 through 5 May 2011; Code 93713*
10. *Infrastruktura PL-Grid [Электронный ресурс]. – Режим доступа: <http://www.plgrid.pl>.*
11. *Laboratory of Computational Mechanics [Электронный ресурс]. – Режим доступа: <http://www.lcm.agh.edu.pl>*
12. A. A. Milenin, A. N. Golovko, I. Mamuzic: *The application of three-dimensional computer simulation when developing dies for extrusion of aluminium shapes*, *Metalurgija*, 41(1) (2002), 53-55.
13. A. Milenin, P. Kustra, *Numerical and experimental analysis of wire drawing for hardly deformable biocompatible magnesium alloys // Archives of Metallurgy and Materials*, 58, 1, (2013) (in press).
14. A. Milenin, P. Kustra, *Sposób i urządzenie do realizacji procesu ciągnięcia cienkich drutów z niskoplastycznych stopów magnezu, zgłoszenie patentowe RP P.397292, 08.12.2011 (in Polish).*

Milenin A. – professor, dr. hab. inż., AGH University of Science and Technology,
Head of Laboratory of Computational Mechanics;

Kustra P. – dr. inż., AGH University of Science and Technology, /

E-mail: milenin@metal.agh.edu.pl; pkustra@metal.agh.edu.pl

Received 12.03.2012.